

GANDALF 25 (GA-90252)



Product description

2 sides



Luminaire Structure

- Die-cast aluminium housing
- Pre-treated before powder coating ensuring high corrosion resistance
- Single cable entry
- One cable gland supplied with 0.5 m of 3x1.0 sqmm outdoor cable

- Stainless steel fasteners in grade 304 with zinc flake coating (ZFC)
- Durable silicone rubber gasket
- Clear toughened glass
- High-efficiency polycarbonate lens

- Integral control gear
- Surge protection 10kV

Optic

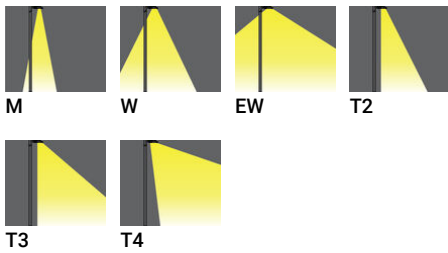

Product colour

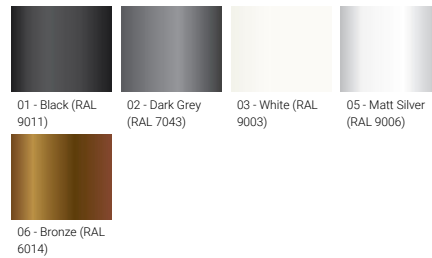

Special finishes upon request

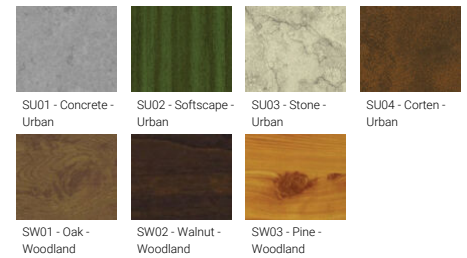

GANDALF 25 (GA-90252)

Technical information

| | |
|----------------------|--------------------------|
| Material | Aluminium |
| Light source | 2 x 48 LED |
| Power | 108 W |
| Lumen | 11554 - 13332 lm |
| Efficacy | 107 - 123 lm/W |
| Driver option | Integral control gear |
| Driver | Constant current (CC) |
| Input voltage | 220-240 V 50/60 Hz |
| Optic | M, W, EW, T2, T3, T4, ME |

| | |
|--------------------------|--|
| Optic value | 30°, 52°, 108°, 144°x47°, 140°x71°, 100°x81°, 139°x59° |
| CCT / CRI | 3000K CRI80, 4000K CRI80 |
| Bug | B1-U0-G1, B2-U0-G0, B2-U0-G2, B3-U0-G0, B3-U0-G1 |
| ULR | 0% |
| ULOR | 0% |
| CIE flux code n°3 | 97, 98, 99 |
| Dimming type | On/Off, 1-10V, DALI |
| Product colours | Black, Dark Grey, White, Matt Silver, Bronze, Concrete - Urban, Softscape - Urban, Stone - Urban, Corten - Urban, Oak - Woodland, Walnut - Woodland, Pine - Woodland |
| Weight | 15.5 kg |

| | |
|---------------------------------|---|
| Operating temperature | -20 °C to 40 °C |
| Cable | One cable gland supplied with 0.5 m of 3x1.0 sqmm outdoor cable |
| Through wiring | Single cable entry |
| Lens / Reflector / Optic | Clear toughened glass, High-efficiency polycarbonate lens |
| MacAdam Ellipse | 3 SDCM |
| Lifetime L90B10 (hours) | > 90,000 |
| Lifetime L80B10 (hours) | > 90,000 |
| Lifetime L80B50 (hours) | > 90,000 |
| Variants (On/Off, DALI) | Compatible with EN/ IEC 60598-2-22: Suitable for emergency installations as central supply, non-maintained (Z0) |

GA-90252

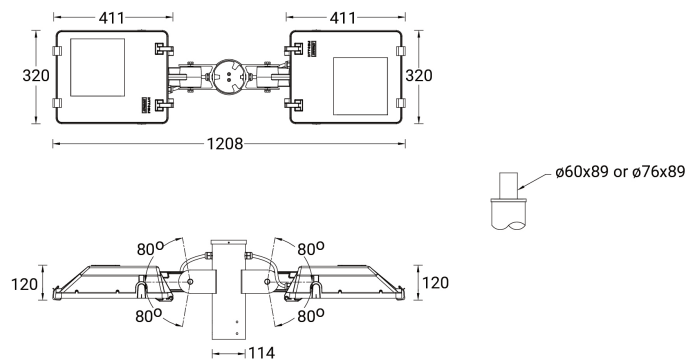

Accessories



DALI Control System
Control-DALI