

QUANTUM 1 (QA-50001)



Product description

Small ** Optic M W VW = 38 W, Optic N = 40 W



Luminaire Structure

- Die-cast aluminium housing
- Pre-treated before powder coating ensuring high corrosion resistance
- Single cable entry, through wiring upon request
- One IP68 connector supplied with 0.2 m of 3x1.0 sqmm outdoor cable

- Stainless steel fasteners in grade 304 with zinc flake coating (ZFC)
- Durable silicone rubber gasket
- High-efficiency optical reflector
- Clear toughened glass

- Integral control gear

Optic

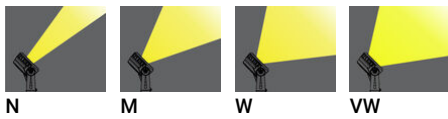

N

M

W

VW

Product colour



01 - Black (RAL 9011)

02 - Dark Grey (RAL 7043)

03 - White (RAL 9003)

05 - Matt Silver (RAL 9006)



06 - Bronze (RAL 6014)

Special finishes upon request

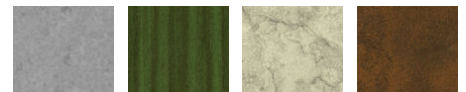

SU01 - Concrete - Urban

SU02 - Softscape - Urban

SU03 - Stone - Urban

SU04 - Corten - Urban



SW01 - Oak - Woodland

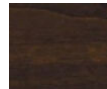

SW02 - Walnut - Woodland



SW03 - Pine - Woodland

QUANTUM 1 (QA-50001)

Technical information

Material	Aluminium	Optic value	21°, 28°, 44°, 75°	Operating temperature	-20 °C to 40 °C
Light source	3 COB	CCT / CRI	3000K CRI80, 4000K CRI80	Cable	One IP68 connector supplied with 0.2 m of 3x1.0 sqmm outdoor cable
Power	38 W	Bug	B3-U0-G0	Through wiring	Single cable entry, through wiring upon request
Lumen	4029 - 4532 lm	ULR	0%	Lens / Reflector / Optic	High-efficiency optical reflector, Clear toughened glass
Efficacy	106 - 119 lm/W	ULOR	0%	MacAdam Ellipse	3 SDCM
Driver option	Integral control gear	CIE flux code n°3	100, 99	Lifetime L90B10 (hours)	> 61,000
Driver	Constant current (CC)	Dimming type	On/Off, 1-10V, DALI	Variants (On/Off, 1-10V, DALI)	Compatible with EN/ IEC 60598-2-22: Suitable for emergency installations as central supply, non-maintained (Z0)
Input voltage	220-240 V 50/60 Hz	Product colours	Black, Dark Grey, White, Matt Silver, Bronze, Concrete - Urban, Softscape - Urban, Stone - Urban, Corten - Urban, Oak - Woodland, Walnut - Woodland, Pine - Woodland		
Optic	N, M, W, VW	Weight	3.7 kg		

QA-50001

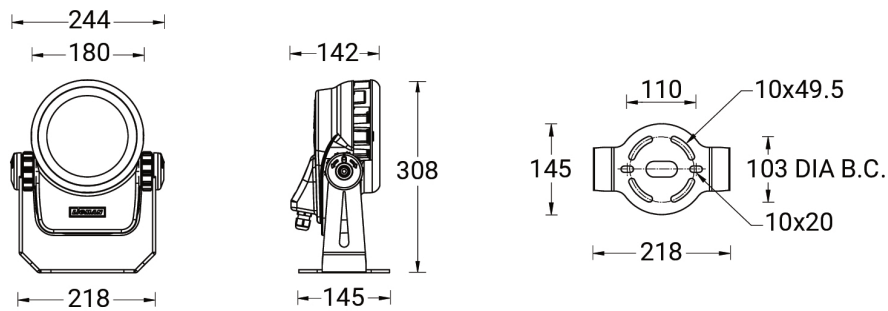

Accessories



Anti-glare louvre
A51421



Linear spread lens
A51614



Anti-glare visor
A53631



Anti-glare hood
A53731

QUANTUM 1 (QA-50001)

DALI Control System
Control-DALI

Please contact the factory for technical details if you wish to use Anti-glare accessories, Colour filters, Lenses and slip glasses in combination.